

Technical Report

CONSTRUCTION OF A ROBOT ARM FOR THE EUROBOT 2011



Verfasser / Matrikelnummer:

Nurain Dzulaidin Tasrin/ S0910564041

Projektleiter:

Dipl.-Ing.(FH) Raimund Edlinger

Abgabedatum:

15.02.2011

Summary

Two alternative designs for Upper Austria University of Applied Sciences, Wels Campus team for their robot arms competing in EUROBOT 2011 are presented.

Design A features the same as design B. However, design B is selected as it is a modified version for design A and it wins in any advantages such as cost, ergonomics, and safety features.

Contents

Summary.....	1
Figures List.....	3
1.0 Introduction.....	4
2.0 Assignment.....	5
2.1 The 2011 Theme.....	5
2.2 Playing Elements.....	5
2.3 Playing Area.....	6
2.4 Robot Dimensions.....	7
3.0 Construction.....	8
3.1 Design A.....	8
3.2 Design B.....	9
3.3 Comparisons between Designs.....	9
4.0 Conclusions.....	10
5.0 Reference.....	11

Figures List

Figure 1: Playing Area.....	6
Figure 2: Protected Area.....	7
Figure 3: Robot Dimensions.....	7
Figure 4: Complete Robot.....	8
Figure 5: Complete Robot with Elements.....	8
Figure 6: Design A.....	9
Figure 7: Design B.....	9

1.0 Introduction

In order to have a completely working robot, a reliable yet competitive design for the robot arm is very essential.

The aim of this project is to design a working arm for the robot of FH Wels in EUROBOT 2011. The arm should follow several criterias including technical specifications, safety features, and competitive points.

This report presents two available designs for the arm. Design A is the original design while design B is the reviewed and modified version.

A description of the design and analysis of operational efficiency of each design are followed by a comparison of the two designs. Finally, the most cost efficient design is recommended.

Eurobot is an amateur robotics contest open to groups of young people from around the world, organized in teams. These teams can be formed by students as part of their studies, by independent clubs or by non-profit organizations. A team must be made up of two or more active participants. Team members may be up to 30 years old, each team may have one supervisor for which this age limit does not apply. (EUROBOT 2011)

The aims of the contest are to promote public interest in robotics and encourage hands-on practice of science by young people. Eurobot is intended to take place in a friendly and sporting spirit. (EUROBOT 2011)

This year theme would be 'Chess Up' where each competing robot needs to fight against other robots in a special chess game.

2.0 Assignment

The task given is to build the arms for the robot. Our strategy is to have 2 grippers with lifters and 2 arms on the robot side. The arm has to be build according to some certain rules by the EUROBOT 2011 Guidelines.

2.1 The 2011 Theme

This year we are playing chess, sort of. As we're playing a special kind of chess ...

In our chess game you can stack the pawns to have more points.

The goal is to have more points on squares of your own color that opponent has on its own at the end of the match.

The matches involve two teams, one playing as *blue*, and the other as *red*. Each team may use only one robot. **Every match lasts 90 seconds.**

The robots begin in the starting zones of their color, located in one of the back corners of the table. The playing elements are available for the robots in different places on the table in various predefined and random positions. **All the playing elements are common to both teams.** (EUROBOT 2011)

2.2 Playing Elements

There will be 3 types of elements to be played which are pawns (which is weigh between 200g and 500g), queens, and kings (which is weight between 300g and 700g).

In total, there will be 15 pawns and 2 queens and 2 kings in total. (EUROBOT 2011)

Dimensions:

Pawns are cylinders with **200 mm diameter** and **50 mm height**. The top and bottom edge (cylinder rim) is cut under an angle of 45 degrees by a few millimetres to allow better manipulation (grabbing) with elements. It is recommended to build them from a PVC tube; top and bottom sides from plywood with a wooden center support column. Another materials can be used as long as weight limits are not exceeded and top/bottom sides have similar magnetic properties as plywood. (EUROBOT 2011)

Each elements will be provided with magnets on its bottom with strength of 5.6kg.

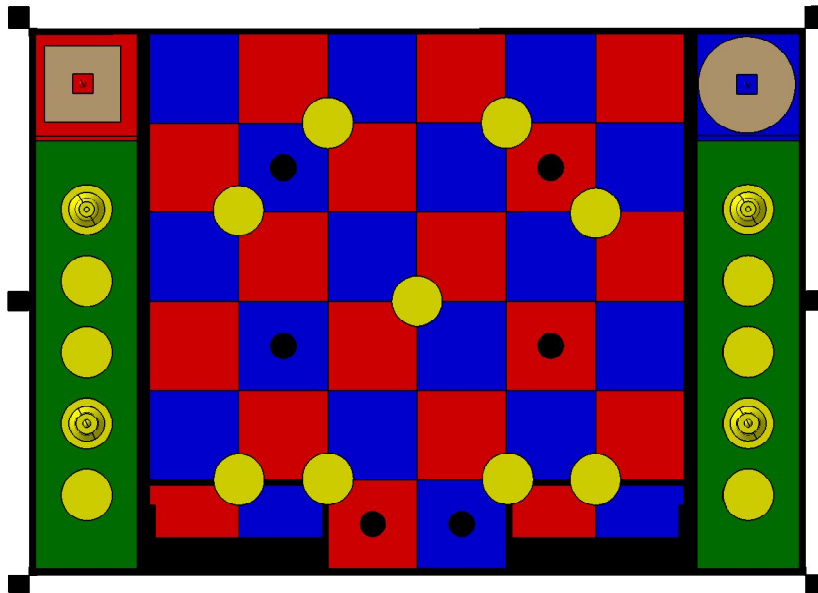

Figure 2: Protected Area [2]

2.4 Robot Dimensions

The perimeter of the robot, in its starting configuration shall not exceed **1200 mm**. The perimeter of the robot in a fully deployed configuration shall not exceed **1400 mm** at any time during the match. The playing elements controlled by the robot during the game are not included in these dimension limits.

The height of the robot shall not exceed **350 mm**, excluding the beacon supporting mast.

However, it will be tolerated that the emergency stop button exceed this height limit, if it does not exceed 375 mm.

(EUROBOT 2011)

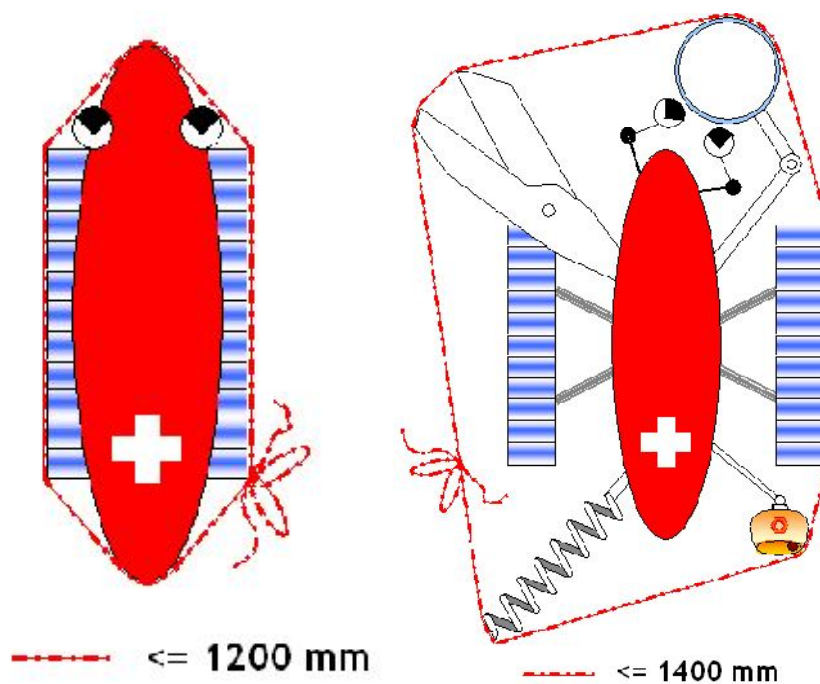

Figure 3: Robot Dimensions [3]

3.0 Construction

As discussed, this project aims to design lifting arms to lift additional elements supporting the complete robot.

Please refer to Figure 4 and 5 for pictures of complete robot.

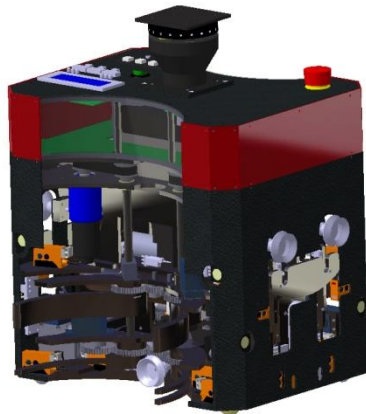

Figure 4: Complete Robot [4]



Figure 5: Complete Robot with Elements[5]

3.1 Design A

The arms of the robot are designed to be placed on both sides of the robot. There are basically 4 parts to build the arms:

1. Plate
2. Vacuum Sucker x 2
3. Infrared Sensor
4. Ball Bearing

The arms should be deployed when the pawn is around certain distance from the robot side. So with this rationality, Infrared Sensor is chosen to be used to detect any pawns nearby.

Two Vacuum Suckers are used. Tests have been done and with two Vacuum Suckers with distance of mm between two of it and it is able to lift the pawn.

Please refer to Figure 6 for complete picture of Design A.

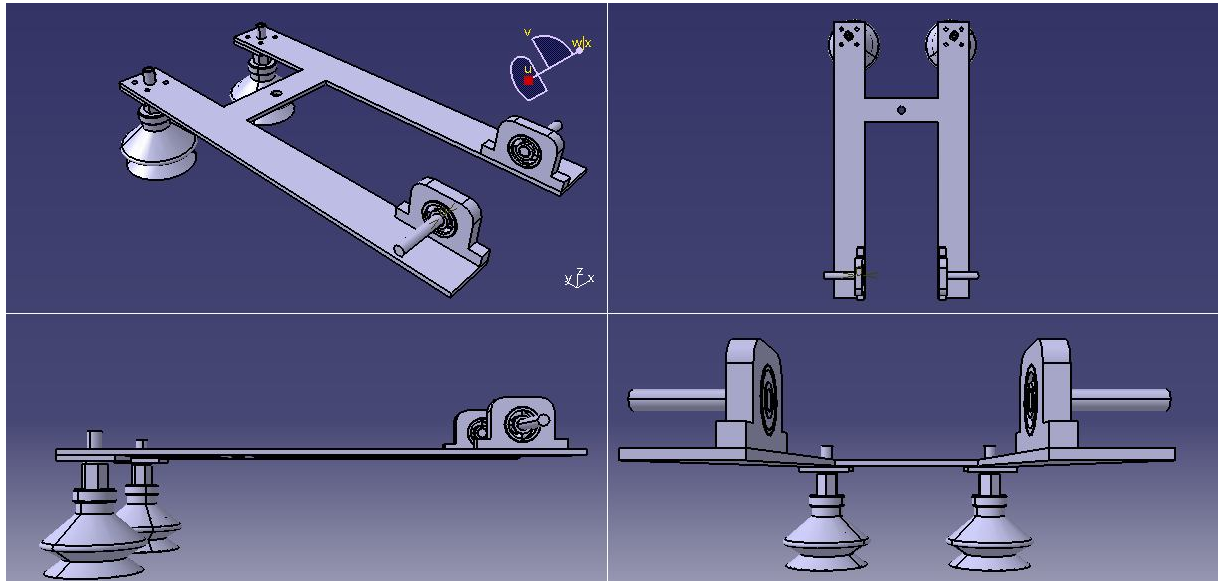

Figure 6: Design A [6]

3.2 Design B

Design B is a modified version of Design A. It presents more detailed features and ergonomical factors.

Please refer to Figure 7 for complete picture of Design B.

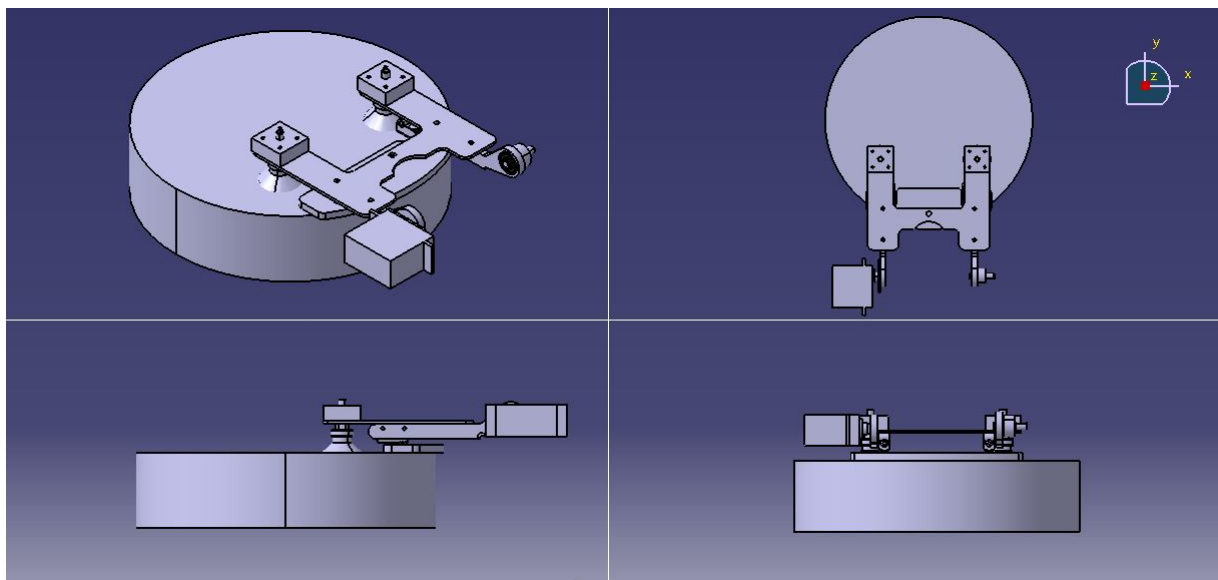

Figure 7: Design B [7]

3.3 Comparisons between Designs

Design A	Design B
- Longer plates, wasting materials	- Shorter plates, reduced cost for materials
- Less ergonomic design, sharp edges	- More ergonomic design, safer edges
- Ball bearing used 624-Z3	- Ball bearing used 625-2Z
- Servo used BLS152 and S3150	- Servo used BLS152 and S3150
- No supporting plate inserted	- Supporting plate inserted under the main plate for more stable element lifting

Infrared Sensors

Infrared sensors are used to make sure the arm will be deployed when the element is in the correct position. The sensors have the ability to detect 4mm distance of the objects from the robot. This will enhance the accuracy of the timing and positioning system of the arms. The specific model of sensors used in the robot is infrared sensor OJ 5002.

4.0 Conclusion

Through many research and development processes, the arms of the robot is done. Designing process took about 2 months to complete while fabricating and assembling the products took about 1 week. There were many testing session done to make sure the mechanical joints of the arm works fine.

Two designs for the arm were presented. Design A presents more simple design and features. While Design B features more detailed and practical factors in many ways. As a conclusion, Design B is chosen to be the arm design of the robot.

5.0 References

[EUROBOT, 2011] EUROBOT org, EUROBOT 2011: Chess'Up!, 2011

[Monash University, 2008] Monash University Language and Learning Online, „Writing in Engineering“, 2008