



Eurobot 2011
Chess'Up !



Rules 2011

Chess'Up !

The robot which has more pieces on its color wins the match.





Eurobot 2011

Chess'Up !



Rules 2011

Table of Contents

1. Introduction.....	5
2. General notes.....	6
2.1. Rules scope.....	6
2.2. Event schedule.....	6
2.3. Refereeing.....	7
3. The 2011 theme.....	8
3.1. The theme.....	8
3.2. Playing elements.....	8
3.2.1. King and queens.....	9
3.2.2. Detection of playing elements.....	10
3.3. Playing area.....	11
3.3.1. Starting zones.....	11
3.3.2. Protected area.....	12
3.3.3. Beacon supports.....	13
3.4. Dispensing zones.....	13
3.5. Scoring.....	14
3.5.1. Game points.....	14
3.5.2. Bonus squares.....	15
3.5.3. Funny configuration.....	16
3.5.4. Penalties.....	16
3.5.5. Match points.....	16
4. The robots.....	17
4.1. General rules.....	17
4.2. Robot dimensions.....	17
4.3. Stickers.....	18
4.4. Limitations.....	18
4.4.1. Fair-play.....	19
4.4.2. Using blowers or vacuum systems.....	19
4.5. Mandatory equipments.....	19
4.5.1. Starting cord.....	19
4.5.2. Emergency stop button.....	19
4.5.3. Automatic shut down.....	20
4.5.4. Obstacle avoidance system.....	20
4.5.5. Robot localization beacon support.....	20
4.5.6. Pilot study.....	21
4.5.7. Technical poster.....	21
4.6. Energy sources.....	22
4.7. Control systems.....	23
4.8. Safety.....	23



Eurobot 2011

Chess'Up !



Rules 2011

4.8.1. On-board voltage.....	23
4.8.2. Lasers.....	24
4.8.3. Powerful lights.....	25
4.8.4. Compressed air systems.....	25
4.9. Other systems.....	25
5. Beacons.....	26
5.1. General comments.....	26
5.2. Robot localization beacon.....	27
5.3. Fixed beacons.....	27
5.4. Communication signals.....	27
6. Match timeline.....	28
6.1. Robot identification.....	28
6.2. Starting procedure.....	28
6.3. Match sequence.....	29
6.4. Calculation of the score.....	29
6.4.1. Game points.....	29
6.4.2. Penalty points.....	29
6.4.3. Match bonus points.....	30
6.4.4. Scratch and match disqualification.....	30
6.4.5. Competition disqualification.....	30
7. Competition phases.....	31
7.1. Approval phase.....	31
7.1.1. Physical examination and team interview.....	31
7.1.2. Practical trials.....	31
7.1.3. Modifications after approval.....	32
7.2. Qualification rounds.....	32
7.3. Final round.....	32
8. Appendix A - Playing area and elements specifications.....	34
8.1. Tolerances.....	34
8.2. Technical drawings of the table and the playing elements.....	34
8.3. References of the paints.....	35
9. Appendix B - Random cards.....	36
10. Appendix C - Technical drawings.....	39



Eurobot 2011
Chess'Up !



Rules 2011

- This page is intentionally left blank -



Eurobot 2011

Chess'Up !



Rules 2011

1. Introduction

Eurobot is an amateur robotics contest open to groups of young people from around the world, organized in teams. These teams can be formed by students as part of their studies, by independent clubs or by non-profit organizations. A team must be made up of two or more active participants. Team members may be up to 30 years old, each team may have one supervisor for which this age limit does not apply.

The aims of the contest are to promote public interest in robotics and encourage hands-on practice of science by young people. Eurobot is intended to take place in a friendly and sporting spirit.

More than a championship for young people or a friendly competition, Eurobot is a opportunity to unleash your technical imagination and exchange ideas, know-how, hints and engineering knowledge around a common challenge. Creativity and interdisciplinary cooperation is necessary to achieve success. Eurobot values fair play, solidarity, creativity and sharing of technical knowledge.

Eurobot takes place in Europe, but is open to teams from other continents. Countries with more than three teams interested in participating must organize a national qualification in order to select the three teams which will participate in the Eurobot finals. The selection will typically include the two best teams (in terms of competition score), but it is left to each national organization committee to agree on a possible alternative to competition for selecting its last team. For example, the third team can be chosen by a jury according to other qualities valued by the contest, such as: best concept, most creative, fair-play, etc. **Note that for countries failing to establish a national qualification event, but with more than 3 teams registered to Eurobot, the refereeing committee will accept only three teams to the event, selecting them based on *the order of submission of their pilot study*.**

Eurobot was founded in 1998, on the strength of the French Cup of Robotics, following the constitution of a similar competition in Switzerland. To deal with the expansion of the contest and to maintain the original spirit of exchange and cooperation between the different organizers, Eurobot association was founded.

You can find Eurobot association's statutes on our website (www.eurobot.org). Individuals or organizations sharing our values are most welcome to support us either financially, or by joining us as volunteers in one of the different organizing groups.

Eurobot and the national qualifications are prepared with passion throughout the year by persons of many nationalities, mostly volunteers, who believe in the educational value of this experience and are themselves often former participants.

Welcome to Eurobot,
and have a nice adventure!



Eurobot 2011

Chess'Up !



Rules 2011

2. General notes

2.1. Rules scope

The following rules apply to all national qualifications and to the finale of the 2011 edition of the Eurobot autonomous robots competition.

In addition, a National Organising Committee, with permission from Eurobot Association, has the right to issue more detailed specifications and restrictions to the rules for a specific country. Check with your national committee for special rules that may apply to you. Regardless of other national rules, all teams which compete in the finale have to meet any rules issued for the country where the finale is held; if they do not follow them, they will not be allowed to compete. We advise you to study these Rules carefully before beginning work on the robot, and to build the robot in conformance with all the rules, both for local national level and for the level of the host of the European final.



Teams that already participated in Eurobot contest in previous years should read the Rules very carefully, as even some common points of these 2011 Rules (not specific to 2011 theme) have changed since 2010 Rules.

2.2. Event schedule

The qualified teams from the national cups of Algeria, Austria, Belgium, Czech Republic, France, Germany, Great Britain, Italy, Romania, Russia, Serbia, Spain, Switzerland and of all other new national qualifications in 2011 will meet their international counterparts (multinational teams and teams from countries without qualifications) during the Eurobot finale.

It is important to note that most of the national competitions, within the limits of their means, are open to the foreign teams. Moreover, numerous teams organize their own friendly competitions. We encourage you to take part in as many competitions as you can, as early as you can - lots of practice will make your robot better!



Eurobot 2011

Chess'Up !



Rules 2011

2.3. Refereeing

Each match is supervised by two referees. For all the matches of the Eurobot finals, at least one of the two referees will be from a country different from both of the competing teams.

The referees are intended to interpret and apply the rules during the approvals and the competition but they are also there to help the teams, for instance by clarifying points about the rules. **You are encouraged to contact the referees with questions about the rules or the competition process.**

Participating in the competition implies the acceptance of the rules and the interpretations of them made by the refereeing committee throughout the year and by the referees during competition matches. The referees' decisions are final and may not be challenged.

A special note to teams participating the French cup: A modification of the approval phase appears this year, please consult the section 7.1 "Homologations" in French version of the rules.



Eurobot 2011

Chess'Up !



Rules 2011

3. The 2011 theme

3.1. The theme

This year we are playing chess, sort of. As we're playing a special kind of chess ...

In our chess game you can stack the pawns to have more points.

The goal is to have more points on squares of your own color that opponent has on its own at the end of the match.

But be careful! All can change in the last second!

The matches involve two teams, one playing as *blue*, and the other as *red*. Each team may use only one robot. **Every match lasts 90 seconds.**

The robots begin in the starting zones of their color, located in one of the back corners of the table. The playing elements are available for the robots in different places on the table in various predefined and random positions. **All the playing elements are common to both teams.**

3.2. Playing elements

The playing elements for this year represent elements of a chess game:

- pawns
- queens
- kings

All the playing elements are completely painted in yellow.

On the table there are 15 pawns and 2 queens and 2 kings in total.

*Number of playing elements carried by a robot at once is **not limited**. However, the robot should not intentionally block the opponent's robot access to any playing elements.*

Weight:

Weight of a pawn is between 200 g and 500 g.

Weight of a queen or a king is between 300 g and 700 g.

Note: Not all elements of a same type have to weigh exactly the same amount!

Dimensions:

Pawns are cylinders with **190 mm diameter** and **50 mm height**. The top and bottom edge (cylinder rim) is cut under an angle of 45 degrees by a few millimeters to allow better manipulation (grabbing) with elements. It is recommended to build them from a PVC tube; top and bottom sides from plywood with a wooden center support column. Another materials



Eurobot 2011

Chess'Up !



Rules 2011

can be used as long as weight limits are not exceeded and top/bottom sides have similar magnetic properties as plywood (see Magnets subsection below).

More information about queens and kings can be found in section 3.2.1.

Detailed specifications concerning the construction and dimensions of playing elements are given in Appendix C. The references of the colors are given on page 35.

Magnets:

All the **pawns** have 2 magnets in their center under the wood on each side of the element. The magnet's south poles are on the bottom side and their north poles are on the top side. There is a small black spot in the center of the bottom side of all pawns, to help the referees to identify correct orientation of pawns on the table.

The **kings** and **queens** have only one magnet, with its south pole on the bottom side of the piece.

The strength of the magnets is approximately **5.6 kg**.

(An example of a suitable magnet is "S-20-05-N" model, which can be purchased e.g. in this on-line shop "<http://www.supermagnete.fr/eng/S-20-05-N>". IMPORTANT NOTE: Eurobot organizers are NOT affiliated with this site in any way, and are not liable for any order nor payment problems, nor warranties.)

Note: The magnets are not primarily meant for element manipulation. The goal of the magnets is to help in building stable towers and to allow identification of valid towers - see section 3.5.1 "Game Points". However, using magnets for element manipulation is not forbidden and *is explicitly allowed* - however, as the actual strength of magnets can vary depending on materials used to build the elements, such a strategy is *not recommended*.



It is totally forbidden to flip pawns upside-down, either by intention or by accident. Such behavior would disallow to use the pawn as a base of a tower (see 3.5.1 "Game Points") and will be penalized.

3.2.1. King and queens

The kings and the queens are built like this:

They are built like a pawn with an optional figure (chess piece) on its top. Exact shape and dimensions of figures is not defined and can differ from one national qualification to another.

The only limitation is, the figures must respect the following conditions:

- they are always totally contained in a cylinder of **160 mm** diameter (on top and in center of the standard pawn base)
- the total height of a king or a queen is less than **230 mm**, including the base

The purpose of the figures is help the audience to distinguish kings, queens and pawns.



Eurobot 2011

Chess'Up !



Rules 2011

3.2.2. *Detection of playing elements*

The kings and the queens can be detected and differentiated by a system of bar-codes.

The bar-code is located on side of king's or queen's base. The bar-code is printed black on a white sheet and is wrapped around the whole length of base cylinder circumference and should be read from bottom to top (first bar-code "letter" is near base bottom, last "letter" is near base top).

Bar-code of queens (word "QUEEN", without the quotation marks, encoded in Code 39 bar-code type):

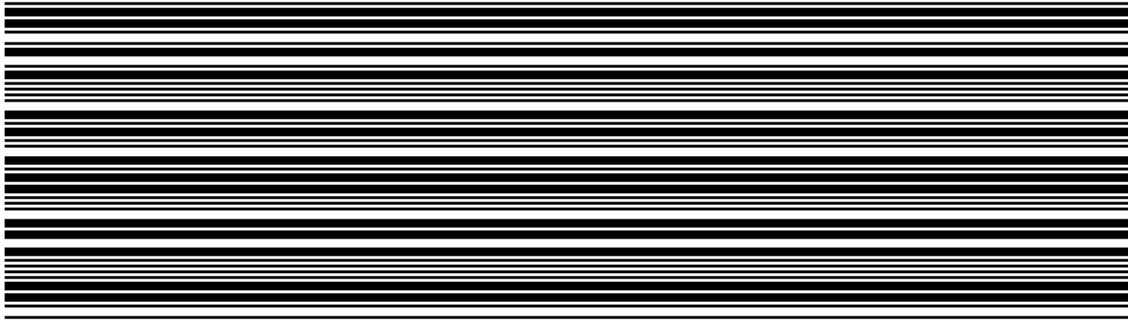

Bar-code of kings (word "KING", without the quotation marks, encoded in Code 39 bar-code type):

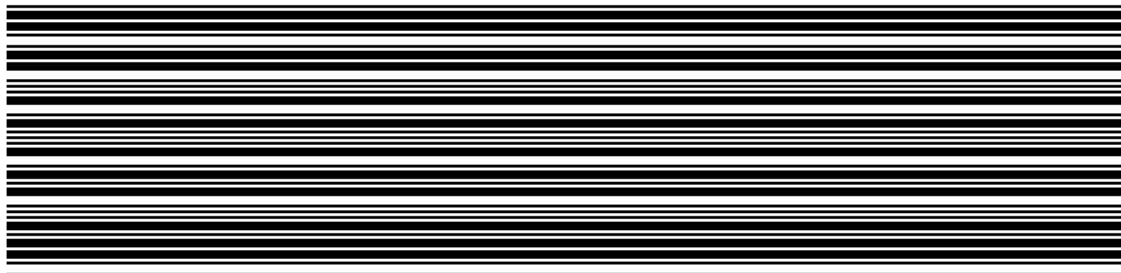

Both types of bar-code - for kings and for queens - are printed in a same resolution and scale (i.e. the area occupied by black stripes is physically higher for queens than for kings).



Eurobot 2011 Chess'Up !



Rules 2011

3.3. Playing area

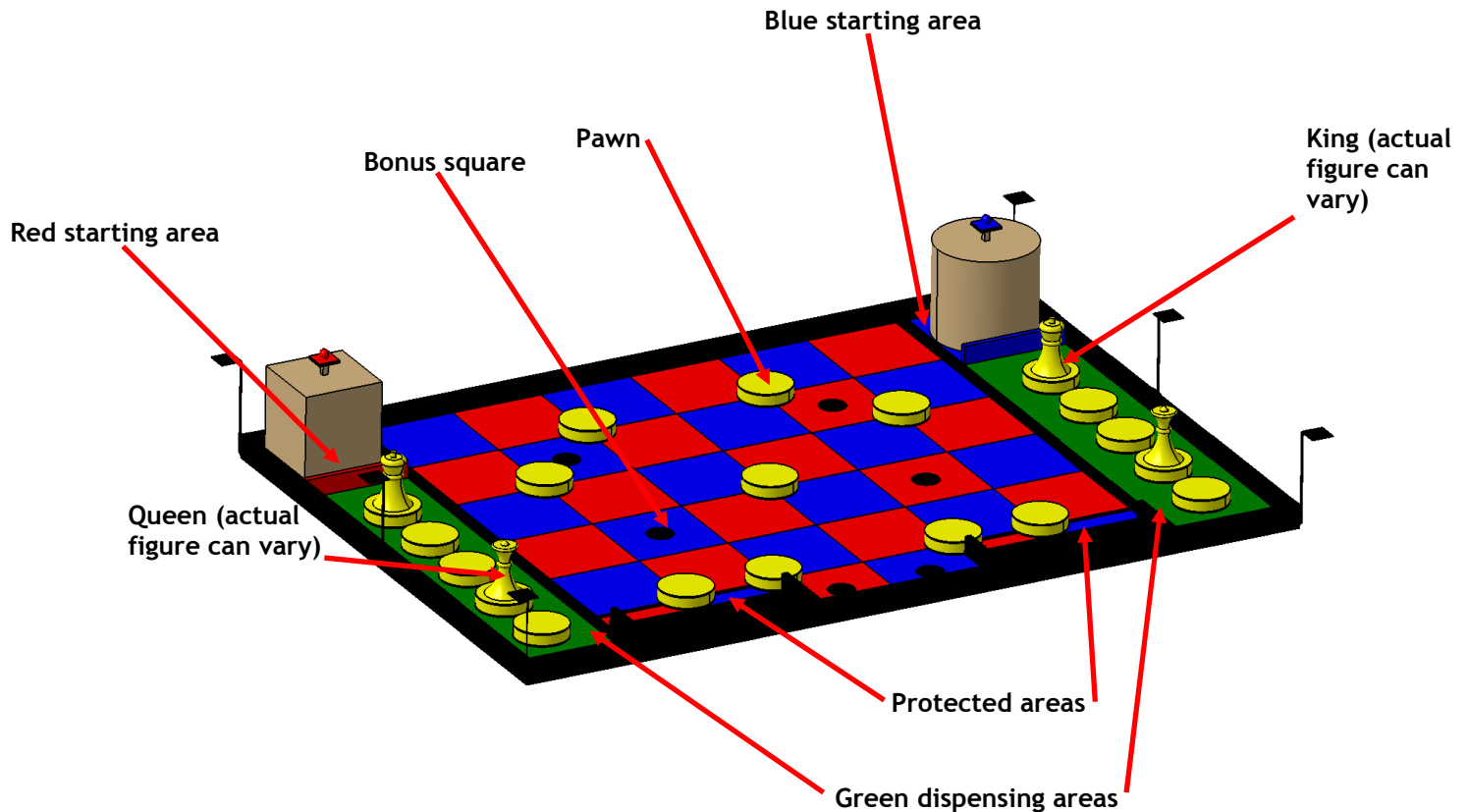

The table is totally plane; only two borders next to the starting area and the protected areas are raised.

3.3.1. Starting zones

The starting zones are placed in the back corners of the table. Each zone is a square, painted in the color of the team (red or blue). At the beginning of the match, the robots must be placed fully contained within these zones. This means that the vertical projection of the robot's convex envelope must fully fit into the starting zone.

Note that this year, the robots do not need to be in contact with the table borders at the start.

This year the starting areas are 40 x 40 cm



Eurobot 2011 Chess'Up !



Rules 2011

3.3.2. Protected area

There are 2 protected areas.

These areas are located in the front of the table.

They each contain two squares (one blue and one red).

Size of these four squares is reduced by 30%, so that only one valid pawn can be physically placed per square in these areas.



*Kings, queens and towers will score as a simple pawn when placed in the protected areas.
It is totally forbidden for a team, or its opponent team, to move any playing elements already placed on a square of the protected areas.*

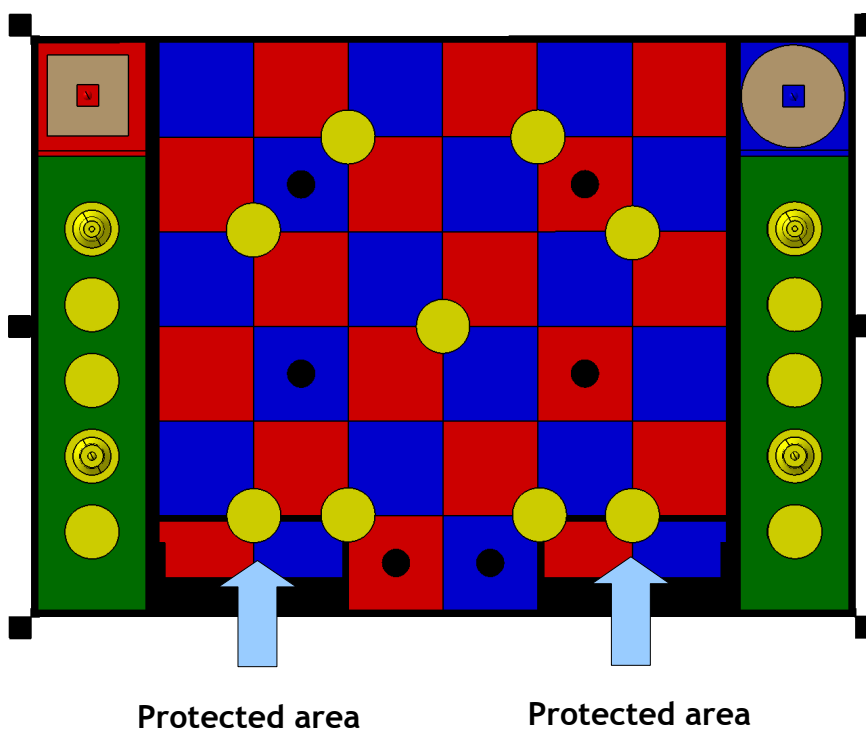



Eurobot 2011

Chess'Up !



Rules 2011

3.3.3. Beacon supports

Robots can make use of beacons to help in localization. Detailed information about and constrains of these beacons are found in the section “Beacons” on page 26. If used, the beacons must be placed on dedicated supports described in this section.

All supports are square platforms. The platform is covered with Velcro (rough “hook” side).

The vertical projection of the beacon supports is outside the playing field perimeter.

Standard beacon supports

- 6 of them are available (3 per one team)
- Their top is placed 350 mm above the table level
- They are located at the table corners and in the middle of each of the shorter sides
- Assignment to the teams is illustrated by the drawing on the right
- They are entirely painted in black

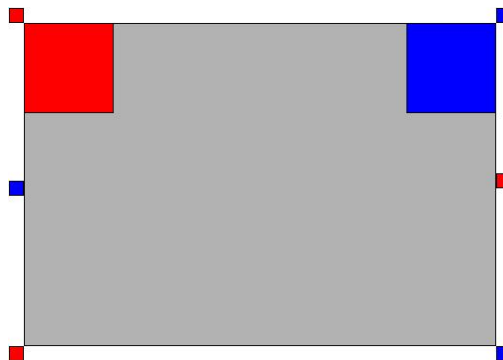

Detailed dimensions are given in the technical drawings.

3.4. Dispensing zones

At the beginning of the match, playing elements are placed in different areas:

- 9 pawns are placed on the ground - the central “chessboard” part of the table. 8 them are placed “randomly”, 1 is placed on a fixed position, see Appendix B “Random cards”. Center of each of these pawns is placed on an intersection of one of theoretical vertical and one horizontal lines separating red and blue squares. Thus, each of these pawns is initially between two red and two blue squares.

Pawns have to be moved inside one of the chessboard squares to become valid and be counted for one of the teams.

- 6 pawns are placed in the two green dispensing areas on each side of the table (3 pawns per one dispensing zone), they are arranged in random positions.
- 2 kings and 2 queens are placed in the two green dispensing areas on each side of the table (1 king and 1 queen per one dispensing zone), they are arranged in random positions.



Eurobot 2011

Chess'Up !



Rules 2011

3.5. Scoring

Points are always counted once the match is over. The score is calculated from points scored during the match (see "Game points") from which any applied Penalties are subtracted as described below.

The team with the higher score is the winner of the match. During the qualification rounds, additional "match points" are awarded depending on the match result.

The different scoring components are detailed in the following sections.

3.5.1. Game points

An element is valid and scored for a team only if: it is contained in a square of the color of this team, AND it's magnet's north is facing directly up.

All three types of playing elements score for different number of points:

- One **pawn** counts for **10** points
- One **queen** counts for **20** points
- One **king** counts for **30** points

In order to score more points you can **stack one or two pawns** on top of each other, and add a **queen or a king** on top - this forms a **tower** (i.e. there are 4 types of towers: pawn+queen, pawn+king, pawn+pawn+queen, and pawn+pawn+king). If such a tower is valid, pawns do not count for points themselves, but act as a multiplier:

- if there is one pawn and a queen or a king, the points of the queen or the king are multiplied by 2,
- if there are two pawns and a queen or a king, the points of the queen or the king are multiplied by 3.



A tower is valid only if: all elements in the tower are "connected" by their magnets (elements are placed on each other concentric enough to stick together by the magnetic force) AND there is a king or queen on the top of the tower.

If two or more pawns are stacked without a king or a queen, the whole stack (invalid tower) scores like a single pawn alone, i.e. for 10 points only.



It is totally forbidden to build a tower in the green area (they cannot be build neither on the area itself, nor inside a robot currently located inside the green area). All the towers have to be build on the central area of the table (the chessboard of blue and red squares).

It is forbidden to destroy or disassemble any valid tower already built, even one built by your own team - such behavior will be penalized. Invalid towers can be disassembled.



Eurobot 2011 Chess'Up !



Rules 2011

Pushing, pulling or otherwise moving towers, as well as single elements, is allowed - as long as none of the previous points are violated.

List of ALL advanced scoring schemes:

A tower of one pawn and a queen score :

20 point for the queen x 2 = 40 points

A tower of two pawns and a queen score :

20 point for the queen x 3 = 60 points

A tower of one pawn and a king score :

30 point for the king x 2 = 60 points

A tower of two pawns and a king score :

30 point for the king x 3 = 90 points

3.5.2. Bonus squares

Every bonus square scores **30** additional points to the team of its color, if there is at least one **valid** playing element placed on it.

This bonus is scored only once per bonus square, even if there are several playing elements on it.

Example of scoring:

A tower of one pawn and a queen + another single pawn - all on a single bonus square:

20 points for the queen x 2	= 40 points
10 points for the pawn	= 10 points
30 points bonus for occupied bonus square	= 30 points
	<hr/>
	= 80 points total

Bonus square location:

There are 6 bonus squares on the table, all placed on fixed locations (see green arrows on picture).

Bonus squares are marked by black filled circles (spots) in the center of each bonus square. The circles are **100 mm** in diameter.

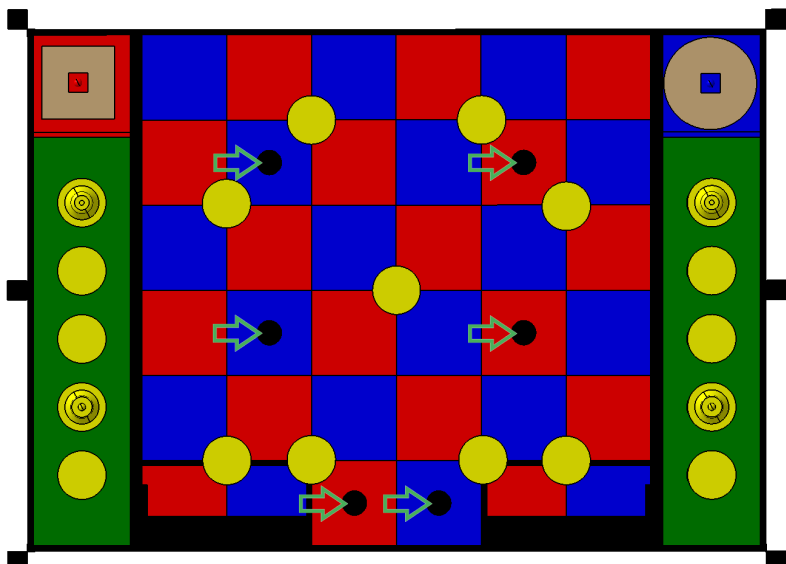



Eurobot 2011

Chess'Up !



Rules 2011

3.5.3. *Funny configuration*

If at the end of the match a robot is ON a single pawn in its own starting area, the robot wins a bonus of 50 points. Only the pawn has to be fully inside the starting area, the vertical projection of the robot does **not** have to fit fully inside the starting area.



“ON a pawn” indicates that the robot touches only the pawn and no part of the robot touches the table, nor the borders!

3.5.4. *Penalties*

Every action that is not fully in line with the rules or the spirit of the competition, *especially* the points noted in paragraph “Penalty points” on page 28, will be penalized.

A penalty consists of subtracting 20% points of the total of points of the team with a minimum of 10 points, at the end of the match. More than one penalty can be issued during one match.



It must be noted that negatives scores are possible if penalties exceed the number of points scored during the match.

3.5.5. *Match points*

A **preliminary total** for the match is calculated by adding scored Game points, points from Bonus squares, points for Funny configuration and subtracting the Penalties. This preliminary total sets the result of the game (victory, defeat, draw, ...).

Match points, based on the following rules, will then be added to the preliminary total to result into a final score. Based on the match result, each team gets the following match points:

- 40 points for a victory
- 20 points for a draw
- 10 points for a defeat
- 0 points for a scratch (disqualification). Preliminary total is **NOT** counted as part of final score in this case.

A score of **0/0 (or below)** is considered as a **double defeat**. Thus, each team gets only 10 match points.



A zero score against a negative score (because of penalties) does not award a victory. It is a double defeat. The team which scored a zero score is counted as a defeat and as a consequence is awarded only 10 points for the match.



Eurobot 2011

Chess'Up !



Rules 2011

4. The robots

4.1. General rules

Each team is allowed to compete with **only one robot**.

It is not permitted to enter the competition with several robots that are **different** (for example, presenting a different robot according to the color attributed to the team for each match).

Every structural modification of the robot during the competition requires another approval phase.

The robot is a fully autonomous machine. It shall carry its own power source, actuators and control system.

The robot is allowed to communicate only with the localization beacons (see section "Beacons" on page 26).

All parts of the robot must remain physically connected - therefore the robot cannot leave parts of itself on the playing area.

4.2. Robot dimensions

Robots can have deployable extensions, their deployment is allowed after the match start signal only.

The perimeter of the robot is defined as the convex envelope which fits the vertical projection of the robot on the ground.

The perimeter of the robot, in its starting configuration shall not exceed **1200 mm**. The perimeter of the robot in a fully deployed configuration shall not exceed **1400 mm** at any time during the match. The playing elements controlled by the robot during the game are not included in these dimension limits.

The height of the robot shall not exceed **350 mm**, excluding the beacon supporting mast. **This height limitation includes any playing elements carried by the robot.**

However, it will be tolerated that the emergency stop button exceed this height limit, if it does not exceed 375 mm.



Caution: if the robot has a diameter less than 180 mm, or is highly transparent, it may be confused with a king or a queen by the opponent robot. **Teams are strongly advised to build their robot, so:**

- that from any angle the robot's width is at least 180 mm
- that from any angle the robot is opaque enough



Eurobot 2011 Chess'Up !



Rules 2011



Unlike the perimeter of the robot, the limitation in height is fixed, both for the starting and the deployed configurations of the robot. No elements can be carried above the limited height. This restriction is set in order not to interfere with the opponent robot communicating with its beacons.

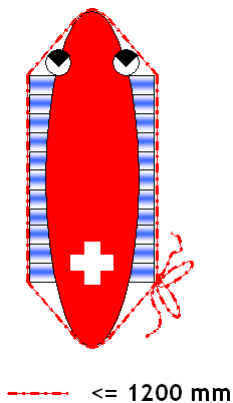

Starting configuration

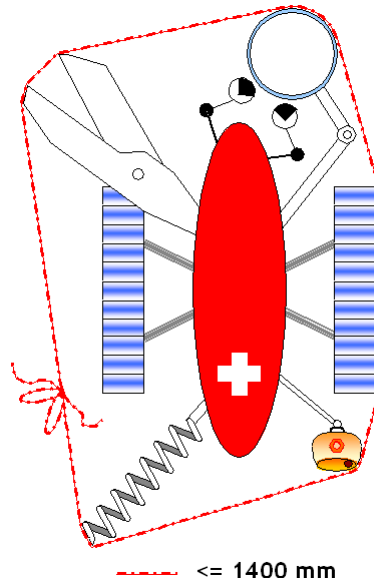

Deployed configuration

Important notice : Since it has been observed that every year some robots are slightly above the allowed dimensions because designed too close to the limits, teams are strongly advised to keep some safety margin, and stay several millimetres under the above mentioned limits, so that no "bad surprises" occur during approval.

4.3. Stickers

Two areas of 100 mm x 70 mm must be available on the robot for the placement of stickers (number of the team and logos of the sponsors of the event, printed by the organizer). The areas should be placed on two different sides of the robot.

4.4. Limitations

The aim is to share a friendly time and play as many matches as possible. Therefore, any action not directly in line with the match spirit as laid out in this document or harmful for match development is not welcome and may be penalised.



Eurobot 2011

Chess'Up !



Rules 2011

4.4.1. *Fair-play*

In the spirit of fair-play, a robot's strategy may not be:

- to block the opponent robot's access to an element or to an area of the playing field,
- to use objects of colors or shapes when designing the robot in order to confuse the opponent.



NONE of the colors mentioned in these rules for the playing elements or parts of the table (i.e. red, green, blue, yellow) may be used on the robot (with the exception of the black color - which is explicitly allowed to be used on the robot; as the black color mostly denotes areas inaccessible to the robot - table borders).

- the robot causing intentional damage to the opponent robot, the playing area, or any of the playing field elements,
- to use a fixing system to attach the robot to the field (e.g. suction cups). At any time during the match, the effort required to lift the robot must not exceed its own weight,
- to use systems designed to make the table vibrate.

4.4.2. *Using blowers or vacuum systems*

The use of blowers to move the playing on the table is **not allowed**.

The use of vacuum systems is **allowed** for gripping and manipulating playing elements.

4.5. Mandatory equipments

All robots must include the following systems, or they will not be approved for competition.

4.5.1. *Starting cord*

The Robot must include a starting device, easily accessible on the robot. It shall be triggered by pulling a cord **at least 500 mm long**. This cord shall not remain attached to the robot after it has been started. Any other system to start the robot (remote control, toggle switch directly activated by hand, etc.) will not be approved.

4.5.2. *Emergency stop button*

The robot must include an emergency off button, with a diameter of at least **20 mm** and painted in **red**. It shall be placed on the top of the robot, in a conspicuous position and in a



Eurobot 2011

Chess'Up !



Rules 2011

zone that is not dangerous and that is immediately accessible to the referee at any time during the match.

The emergency stop button can exceed the maximum height of the robot by 25 mm (total height of the robot possible including the emergency stop button is 375 mm).

The stop button must be activated by a simple downwards pushing motion.



*Pressing the emergency button must result in the immediate shut down of all of the robot's actuators, leaving them limp (**neither actively braked nor energized**). This includes all drive motors, actuator motors, internal systems and all other moving parts of the robot.*

The emergency stop button must also immediately shut down all laser devices used in the robot.

4.5.3. Automatic shut down

Each robot must implement a system which must stop the robot automatically at the end of the **90 second** match duration. "Stop" implies complete shut down of all actuation including internal devices. Robots moving after the end of the match will be penalized or disqualified.

4.5.4. Obstacle avoidance system

Teams are required to equip their robots with an obstacle avoidance system. The system is intended to prevent collisions and damages between robots during a match.

The robot must be able to avoid at least a fake robot, as described in paragraph "Practical trials" on page 31.

4.5.5. Robot localization beacon support

It is strongly recommended to design the robot with a support to accommodate a localization beacon prepared by the opponent team.

If desired, the support can be designed to be detachable, so that it is only used if the opponent needs it. In this case the design must allow the support to be quickly attached before the match.

A team may choose not to include a beacon support. In this case, if the opponent provides a beacon and wants to use it during the match, the team will be disqualified for not having the support.

The beacon support shall at all times comply with the following constraints:

- It is a **80x80 mm** square surface, located **430 mm above the floor level**. The structure supporting this platform must stay within the vertical projection of this platform. This mast cannot host any parts of the robot other than sensors. The mast shall be robust and rigid enough to support the opponent's beacon in a stable fashion. The team is responsible for the robustness of its mast.



Eurobot 2011

Chess'Up !



Rules 2011

- The platform surface of the support shall be fully covered with Velcro™ (rough "hook" side)
- The platform must be stable and support at least 300 g.



This point will be checked during the approval phase.

- The support shall be located close to the horizontal centre of the robot. In the robot's not deployed configuration, the distance between the support and the maximum robot extension on one side shall not be less than 50% of the equivalent distance on the opposite side.

4.5.6. Pilot study

Each team is required to submit a pilot study.

The pilot study should be written in advance of building the robot and should provide a concise vision of team's project focusing on 2 topics:

- General information (team, planning, budget)
- Technical information (strategy, technical choices, etc.) - should contain details about mechanics, electronics and software team plans to use. If possible it should include illustrative diagrams and pictures. This part must be written using a give template (downloadable from the registration website).

The pilot study must be written in English or French, must be at least 2 A4 pages long and should be submitted as soon as possible after the registration and must be submitted before the registration deadline.

The goal of the pilot study is not to give the teams more work, but to help them finalize their project successfully. It will be studied by the refereeing committee in order to identify possible misunderstandings of the rules, etc. as soon in the development process as possible. Thus it will allow us to recognize doubtful solutions and to help teams to avoid failure situations.



The pilot study is part of the registration process and is mandatory. Teams that have not submitted their pilot study by the registration deadline are considered not registered!

4.5.7. Technical poster

Each team is required to provide a technical poster.

This poster should present information related to the design of the robot (drawings, technical references, design specifications, etc.). It should be at least DIN A1 in size, and ideally should be printed. The poster is intended to promote exchange and communication between teams.



Eurobot 2011

Chess'Up !



Rules 2011

Effort should be made to make the poster understandable to a non-technical audience. Ideally the poster should include pictures and diagrams to help explain the concepts.

The poster must also include:

- the name of the team,
- the names of the team members,
- the nationality of the team.

This poster will be displayed in the team's pit. **An English version of the poster must be supplied.** Optionally, the team can provide other language versions as well.

The poster shall be supplied to the Eurobot association in **PDF Format**. The chosen resolution of the PDF must guarantee that all texts on the poster will remain readable. If possible, the file size of the PDF should remain below **25 MB**. The PDF Version of the poster may be sent to Eurobot beforehand via your National Organisation Committee, or may be provided on CD-ROM or USB key at the competition, during the approval for your robot.

In general Eurobot encourages the teams to communicate about their projects, for example by posting information on Internet, in the Eurobot forums, etc.

4.6. Energy sources

Allowed energy sources include springs, pressurised gas, solar cells (note that the competition will be held indoors) and most types of commercially available batteries and power cells.

Prohibited energy sources include all types of combustion engines, rocket engines, hydrogen fuel cells, any other type of burning or pyrotechnics, living beings and radioactive energy sources of all types.

If in doubt about your unusual energy source, ask the refereeing committee ahead of time.

With respect to batteries, use only models with solid electrolyte in order to prevent any problem with corrosive liquids.

It is strongly recommended for teams to possess several battery sets and to design for easy access in the robot for their replacement. The teams are reminded to have spare, fully-charged batteries available at all times.

Teams are required to be capable of playing two matches in succession. Note that this includes the necessary "set-up time", when the robot is powered on and waiting to start, but the match has not yet begun.



Eurobot 2011

Chess'Up !



Rules 2011

4.7. Control systems

The teams may use any kind of robot control system (analogue, microprocessors, micro-controllers, computers, programmable logic, etc.).

Those systems must be fully integrated into the robot.

The control system must permit the robot to play a match as either color. The color of each team will be decided just prior to the match.

The control system must permit the robot to pass the approval phase.

4.8. Safety

One of the design goals for your robot should be to develop systems that are safe for people, both during the competition and during the construction and experimentation phase of your project. This is also why you must ensure that your systems comply with applicable

The robots must not have any protruding or sharp parts that may be able to inflict injury while casually handling the robot. The use of liquid products, corrosive products, pyrotechnic materials or living beings in the robot is also forbidden. Each of these points will be checked during the approval phase of the competition, before the robot is allowed to participate to matches.

As a general rule, any device or system considered as potentially dangerous by the referees will be rejected, and must be removed from the robot prior to competition, or result in the team's disqualification.

All the systems on the robots shall respect existing national and European laws and specifications. Specifically, the systems used shall comply with legal safety regulations and must not endanger the participants or the public both during matches and backstage.

Hereafter are listed some safety regulations. This list is not exhaustive - the referees' decisions are final on what is dangerous, and what is not.

Teams not complying to these rules (by providing incorrect documentation for instance) will be held responsible in front of the justice in case of any damage resulting from their system.

4.8.1. *On-board voltage*

All robots must comply with the legal standards concerning "low voltage". Therefore, the internal voltage of the robots **shall not exceed 48 V**.

Internal voltage is defined as the electrical potential between any two parts of the robot, with or without its casing in place. This includes components insulated by the teams themselves, using adhesive tape, thermo-shrinking tubing, or any similar non industrial process.



Eurobot 2011

Chess'Up !



Rules 2011

It is permitted that potentials higher than 48 V exist, but only inside sealed commercial devices (such as lasers or LCD display back lighting) and only if these devices have been left unmodified, and themselves comply to national and European regulations.

4.8.2. Lasers

Only considerations based on laser class definition (in the "EN 60825-1:2007, Edition 2 - Safety of laser products - Part 1: Equipment classification and requirements" standard) will be taken in account. Teams using a laser will have to provide the classification notice of the equipment, or the data sheet of the laser component. Not being able to provide such documents will prevent the robot to be approved as is.

Based on the classification, it is allowed to use lasers of Class 1, 1M, 2, 2M. All other classes (3R, 3B and 4) are strictly forbidden.



Additional constraints for robots competing in France : Lasers class 2 and 2M are accepted if and only if the laser beam is never projected outside the table.

For safety reasons, laser components salvaged from CD/DVD readers or writers are not allowed. Even if these consumer devices are classified as class 1 laser devices, this classification is valid only if the device is kept unmodified and with its casing in place. Lasers components included in such devices can be class 3 because of its wavelength and/or energy used. Therefore it is not permitted to use these components in the competition.



CAUTION: disassembling such products and have them operate without their casing can be extremely harmful (this is indicated by the stickers that should be present on the casing of the device)

Robots using class 2 and 2M lasers must show on their casing a laser caution label according to the official laser products users guide (IEC TR 60825-14: 2004 Safety of laser products. A user's guide), such as the following one:

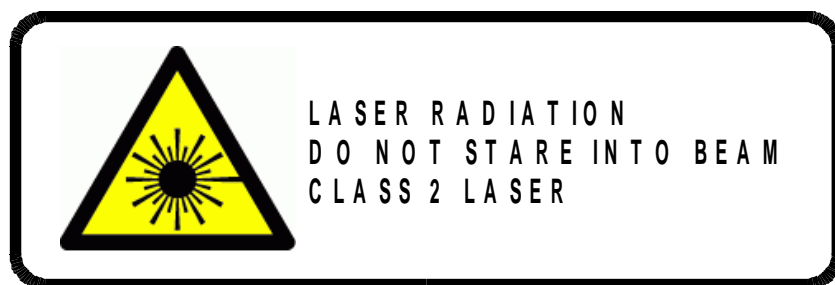



Eurobot 2011

Chess'Up !



Rules 2011

4.8.3. *Powerful lights*

When high intensity light sources are used, be aware that the light intensity can be dangerous for the human eye. Note that some commercially available high power LED devices can exceed this limit.

4.8.4. *Compressed air systems*



This paragraph applies to all robots competing in France.

All pressure systems must comply with the “Conseil Général des Mines” Decree 63 of January 18, 1943 and Ministerial Order of July 25, 1943:

- Maximum service pressure : 4 bars
- Maximum pressure x Tank volume \leq 80 bar.liter

Further information can be found on <http://www.industrie.gouv.fr/sdsi/>

4.9. Other systems

All other systems are, in principle, allowed, provided of course they comply with the rules outlined above. Use your imagination!

For example, in order to encourage innovation and provide an interesting show for the public and media it is suggested to implement sound or emotive behaviours into your robot.



5. Beacons

5.1. General comments

Beacons are not allowed to obstruct the opponent robot. If there is any doubt that they may deliberately disturb the development of the match, the team will not be allowed to use them.

The beacon supports are placed in the locations detailed in paragraph "*Beacon supports*" on page 10. They are placed on the outside of the table.

The beacons undersides (bottoms) are covered with Velcro (soft "loop" side) as a way to fasten them on their assigned support.

The beacons (robot localization or fixed ones) shall remain on their support throughout the matches.

The use of beacons is optional.

All safety standards applicable to robots are also applicable to the beacons.

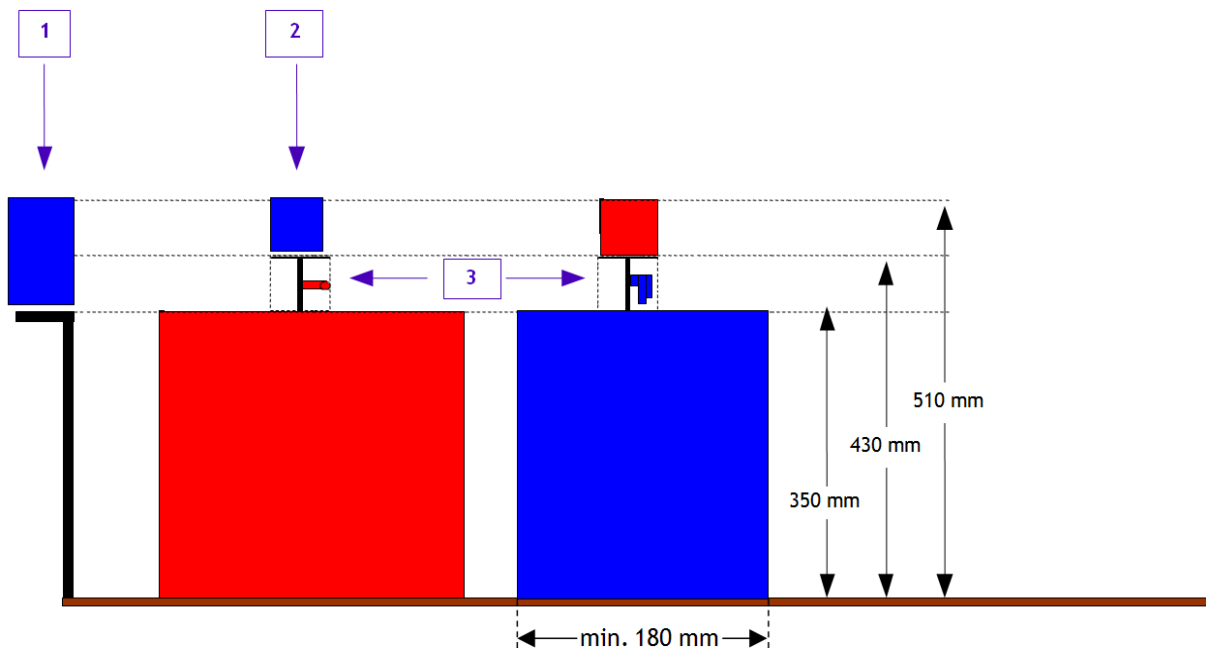

Legend :

- 1: Fixed beacon (maximum dimensions L x W x H: 80x80x160 mm)
- 2: Robot localization beacons (maximum dimensions L x W x H: 80x80x80 mm)
- 3: Mast (area for sensors and associated components only, provided that they remain within the vertical projection of the support of the beacons)



Eurobot 2011

Chess'Up !



Rules 2011

5.2. Robot localization beacon

One localization beacon can be fitted onto the other robot, in order to locate it. This beacon will be fitted on the beacon support provided for this purpose by the opponent robot.

Only one localization beacon is allowed per team.

The maximum size for a robot localization beacon is a **cube with 80 mm sides**.

The elements used for the beacon design shall be all useful. If necessary, the referee may request that the team opens its beacon casing for inspection and verification.

The robot localization beacon top shall be covered with **Velcro (rough "hook" side)** able to support the flag module identifying the robot's allocated color.

5.3. Fixed beacons

Each team can put a beacon on any of the fixed beacon supports assigned to it placed around the playing area. See paragraph "**Beacon supports**" on page 10 for details.

The fixed beacons must remain within a square base of **80x80 mm** and can be up to **160 mm high**.

The fixed beacons can be linked together by a wire. This optional wire must not disturb the development of the match and the team must be able to install it during the 3 minutes for match preparation without disturbing the opponent team.

Temporary wire connection between the beacon and the robot is allowed during the preparation phase before the match, but on the definite condition that it doesn't disturb the preparation of the opposing team. In case of a justified complaint from the opponent, the team will have to cease using this equipment.



Given that the 3 minutes time period allowed for the preparation is very short, and that any team not respecting it will be penalised, we strongly advise against the use of such equipment (beacon physical wire connection).

5.4. Communication signals

In order to avoid interference between the teams, it is recommended to encode the communication signals. **We strongly recommend that teams using infra-red devices take into account the VERY STRONG ambient light used during the competition.** The professional stage lighting systems emit large amounts of light and heat energy! Moreover, this illumination may vary over time and location during the competition.

We also mention that the competition staff uses high frequency radio devices during the contest.

No complaint regarding interference problems will be taken into account. The beacons must be able to cope with the conditions that may change depending on the moment and their location during the contest.



Eurobot 2011

Chess'Up !



Rules 2011

6. Match timeline

6.1. Robot identification

For each match, the robots are allocated a team color marker, built as a small flag module in red or blue. The marker is to help the public recognize which robot belongs to which team.

The flag module mass is negligible. It is placed directly on the robot beacon support, or directly on the robot. **If the robot does not provide a beacon support, it must provide a 80x80 mm square surface covered with Velcro™ (rough “hook” side) at the top of the robot to place the flag marker on.**

6.2. Starting procedure

- A color (red or blue) and therefore a side of the playing area is allocated to the team before each match.
- **Only 2 members** from each team are allowed to access to the stage area for robot preparation.
- Both teams have 3 minutes to put their robot on the starting position, to prepare it and to install all beacons.
- The robots are placed on the table, entirely within their starting areas.
- After the **3 minutes** preparation time, no more intervention or transmission of external information to the robot is allowed.
- When both teams and the referees indicate they are ready, the referee will determine the random positions for the playing elements to be placed on the table. This is done by drawing from a set of cards. These cards are provided in the Appendix of this document (“Appendix B - Random cards” on page 35). During and after this procedure, the teams are not allowed to touch their robot nor communicate with it.
- The referee asks the participants if they have any remark about the placement of all the game elements. *Any mistakes can be corrected by the referees only.* No objection regarding the placement will be accepted after this point.
- At the start signal given by the referee, the robot is activated by one of the team members using the starting cord. The robot shall then run on its own in a fully autonomous way.

Any team which does not scrupulously follow this starting procedure is charged with a **false start**. A new start shall be given with a new random layout for the game elements. Penalties may be applied for causing the false start.



Eurobot 2011

Chess'Up !



Rules 2011

6.3. Match sequence

Robots have **90 seconds** to score as many points as possible. This must be accomplished in complete autonomy.

The team members are not allowed, in any way, to touch the robots, the playing area or any of the playing elements during a match. **Any such action made without the referees consent will lead to disqualification for the current match. The team will then lose all the points it may have scored during the match.**

If the robot leaves the playing area it may not be put back in. The match is not replayed and the other robot is allowed to finish the match normally.

A robot that deliberately pushes its opponent out of the playing area is disqualified.

At the end of the match, the robots must stop (shut down of all actuation) by themselves. If the robot does not shut down by itself, a referee will push the emergency stop button to stop the robot.

The referees will count the points without touching the robots. Then they will announce the score.

The team members are allowed to touch the robots and leave the game only with the explicit consent of the referees after common agreement on the score. They must ensure that no playing elements remained inside the robot.

6.4. Calculation of the score

6.4.1. *Game points*

Game Points (see “Scoring” on page 12) are awarded at the end of the match for the game actions connected to the playing elements.

6.4.2. *Penalty points*

A penalty results in the removal of points from the score of the team at the end of the match. Any action not compatible with the spirit of the rules may be penalized by the referees. **For example**, the referees may assign penalties in the following cases:

- When a robot violently collides with its opponent.
- When a robot is considered dangerous for the table, the audience or its opponent.
- When a robot deliberately prevents its opponent to access a game element.
- If a robot's shut-down system fails to work.
- If the robot puts systematically playing elements off the table.
- Whose robot shows a deployment or an action that has not been previously approved by the referees, or any deliberate action not in line with the rules.



Eurobot 2011

Chess'Up !



Rules 2011

Additional penalties can be applied if the referees consider this justified. For instance, if a team has been warned about some negative point during a match, and the same point is noticed during a subsequent match, this will turn into a penalty. The electronic scoring system used for the competition sports a feature to record such warnings, so that the referees can know about past problems with the teams and take them in account accordingly.

Multiple penalties can be applied for one offence, if the referee feels the offence justifies it.

6.4.3. Match bonus points

Additional points are awarded in the qualification rounds to the teams accordingly to the result of a match. The system of bonus points is described in paragraph “Match points” on page 12.

6.4.4. Scratch and match disqualification

The team is declared scratched (i.e. disqualified from the current match) when some of the following conditions occur:

- it does not come on time to the backstage waiting room for matches;
- it takes more than 3 minutes to get ready on the playing area;
- its robot has not completely left its start area during a match;
- its robot doesn't have a mobile beacon support, when its opponent requests and requires one.

In case of a scratch, no points are given to the team (whether positive or negative).

6.4.5. Competition disqualification

The referees may disqualify a team for the competition:

- when the robot makes the same penalized actions systematically;
- for unacceptable behavior;
- failure to comply with safety regulations;



Eurobot 2011

Chess'Up !



Rules 2011

7. Competition phases

7.1. Approval phase

A robot must be approved before being allowed to participate in the tournament. For logistical reasons, and reasons of fairness, there is a deadline for approval. All teams must approve their robots before this deadline. Robots that are not approved will not be allowed to participate in the tournament.

7.1.1. *Physical examination and team interview*

The referee examines the robot and interviews the team to check the following:

- That the robot complies with the rules (the robot should be capable of demonstrating all of its possible actions and deployment configurations to help verification).
- That the team provides a required technical documentation of components (e.g. lasers).
- That the team provides a technical poster.
- That the team understands the rules and the spirit of the tournament.
- That the emergency stop button works, and all actuators are shut down when it is pressed.
- The organizer's logo (if required) is placed on the robot so it is visible by the public.

7.1.2. *Practical trials*

In addition, the robot must pass the following tests:

1. That under match conditions, without opponent:
 - The robot is capable of leaving the start area
 - The robot is able to score at least 10 points.
 - The robot's shut down system works properly
2. A test that the robot's obstacle avoidance system works.

The system should be able to successfully avoid a static dummy obstacle, put in the path of the robot. This obstacle is a fake robot made of a 300 mm high and 200 mm diameter cylinder, weighting between 2kg and 3kg. This fake robot has a beacon platform, so that it is possible to place a beacon on it. The robot must not move the obstacle, demonstrating to the referees in a convincing manner that it properly takes the obstacle in account.



Eurobot 2011

Chess'Up !



Rules 2011

3. For competitions held in France, in case of class II lasers (be it in the robot or in the beacons) the laser system is tested to ensure that the spot is never projected outside the table.

7.1.3. *Modifications after approval*

It is mandatory to keep referees informed of any major modifications (functionality, size, etc.) performed after the robot's approval. The referees will check the modifications and re-approve the robot.

Actions used during the match which were not demonstrated during the approval process can lead to penalties or disqualification.

Referees can require a robot to subject itself to another approval process at any time during the competition, if in doubt about its conformance to the rules.

7.2. Qualification rounds

The qualifying rounds consist of at least 5 matches for each team during the qualification round. The results of the qualification rounds decide which teams go to the final round.

When the qualification rounds are over, the teams are sorted using their cumulative qualification point count. The teams that have the **same points** count are sorted by comparing the **points** accumulated during each match **without adding the bonus match points** for match result.

In case of ties, the organisers may request the teams to play extra matches. Pairs of teams competing for the same rank will be randomly drawn, and resulting matches will be played on a knock-out basis. In case of odd number of teams, an additional random match will be played, on the same basis.

7.3. Final round

At Eurobot finale, the first 16 teams from the qualifying phase are selected for the final round. In a national competition the final round may be smaller, depending on the number of registered teams.

The matches for the final round are organised as shown in the diagram here after.



Eurobot 2011 Chess'Up !



Rules 2011

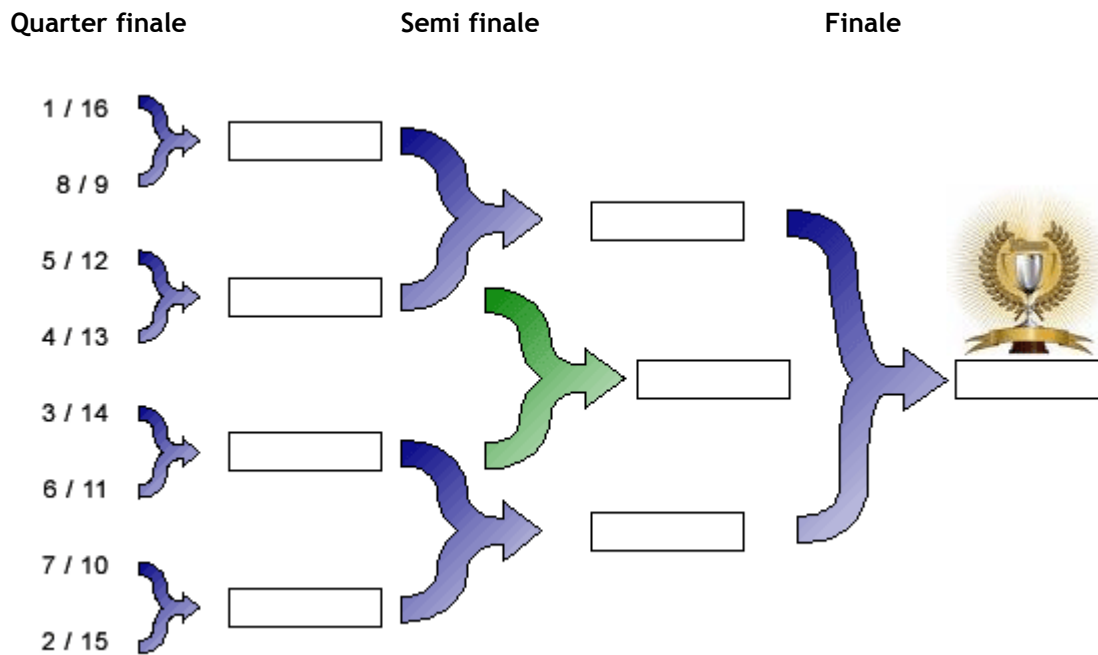

3rd rank finale

During the final phase, matches are on a knock-out basis.

In the event of a double defeat, a draw or a double disqualification the match is **replayed immediately**. If this second match is also a double defeat, a draw or a double disqualification, the winner will be determined **by the position at the end of the qualification rounds**.

The final match is played in **two winning sets**.



Eurobot 2011

Chess'Up !



Rules 2011

8. Appendix A - Playing area and elements specifications

The following section provides all the details necessary for playing area construction.

8.1. Tolerances

The organisers are committed to build the playing area as precise as possible. But they are allowed for fabrication tolerances. Exact tolerances are **not** specified this year - **the teams are strongly advised to build their robot hardware & software as robust as possible!** The reason for this change is to help the teams to be better prepared for any future real life challenges.

No complaints related to table or playing element fabrication will be accepted. The teams are also warned that the paint finish of the table may vary from one playing area to another and may degrade during the competition. Note that especially the glossiness of the table can vary a lot.

If problems with the rules are discovered, the definition of the field and game components may be modified over the course of the year. We strongly advise participating teams to regularly consult our web site <http://www.eurobot.org/> in the 'FAQ' section for potential amendments and to follow the discussion and the information on the forum <http://www.planete-sciences.org/forum>.

Important notes:

Be aware that the flatness of the table is also subject to some variation. While some tables are made of very stiff materials, and perfectly flat, some are softer and may have some degree of warping. The tables may also be made from two or more sections, resulting in a small ridge at some locations on the table surface. For these reasons it is urgently recommended to allow enough flexibility in the robot's drive system, and the robot's clearance to accommodate such variations.

Above tolerances apply to the playing field and other components of the game only. They do NOT apply to robots and localization beacons prepared by the participating teams, which are required to respect the limitations described in this document, without tolerances.

8.2. Technical drawings of the table and the playing elements

Because of their size, the detailed technical drawings with dimensions are gathered in "Appendix C - Technical drawings" on page 39.



Eurobot 2011

Chess'Up !



Rules 2011

8.3. References of the paints

Element	Color	Type of paint	Reference
Blue squares, blue starting zone, border between blue starting zone and adjacent dispensing area	Blue	Acrylique, mate	RAL 5017
Red squares, red starting zone, border between red starting zone and adjacent dispensing area	Red	Acrylique, mate	RAL 3020
Dispensing area	Green	Acrylique, mate	RAL 6024
Playing elements	Yellow	Acrylique, mate	RAL 1023
Table borders, borders of protected zones, border line between chessboard and starting, dispensing and protected areas, spots on bonus squares, beacon supports	Black	Acrylique, mate	RAL 9017



Eurobot 2011 Chess'Up !



Rules 2011

9. Appendix B - Random cards

There are 20 cards for the random positions of the playing elements:

At the beginning of each match, the referee will draw 3 cards:

1. First card indicates the position of the king and the queen in the green dispensing areas. Remaining 3 positions in dispensing areas are filled by pawns.
2. Second card indicates the position of the 2 pawns on the first line of the chessboard grid on each side.
3. Third card indicates the position of the 2 pawns on the second line of the chessboard grid on each side.

Thus, initially there are 2 pawns on each Line 1 and Line 2. Pawns are located on intersections between squares.

The playing elements are placed in symmetry around the short axis of the table (Central Line).

On the central line of the grid, there is only one pawn, in a fixed position the center.

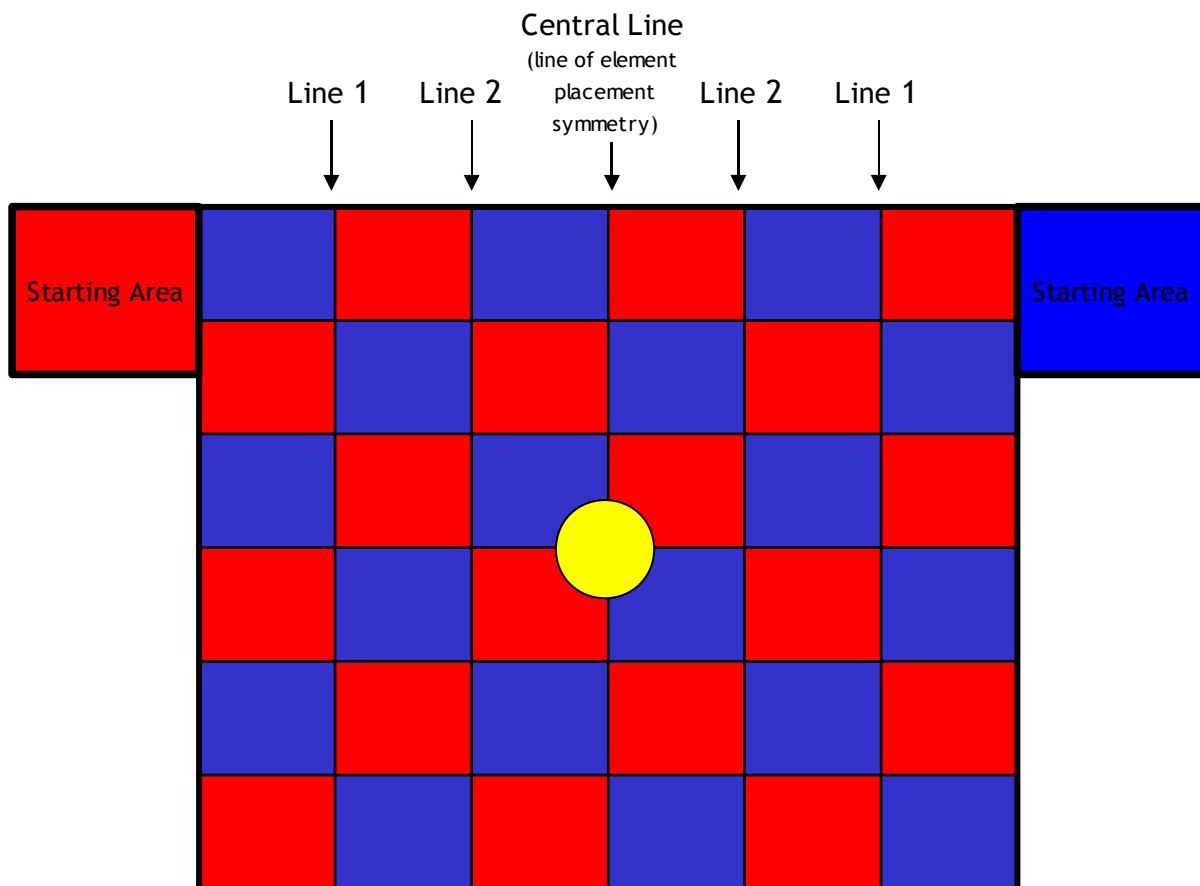

36/39



Eurobot 2011 Chess'Up !



Rules 2011

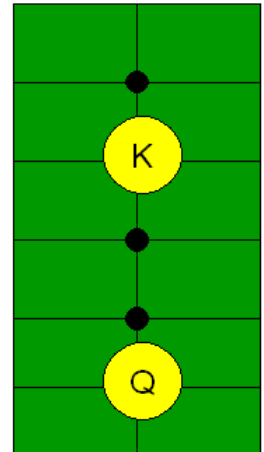
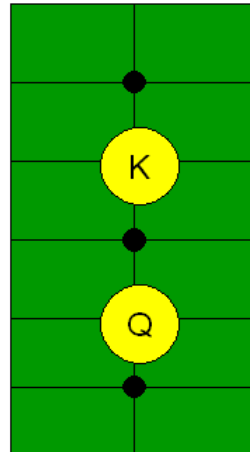
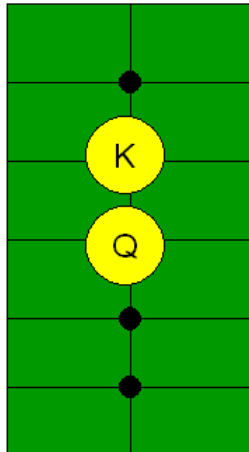
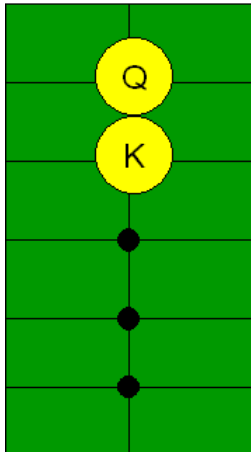
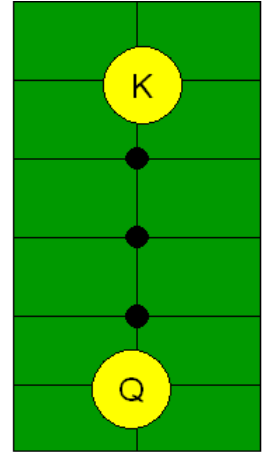
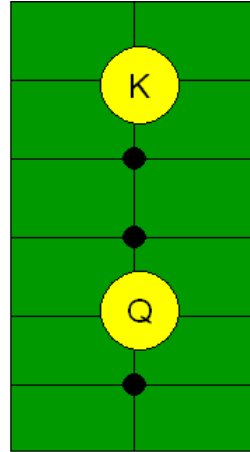
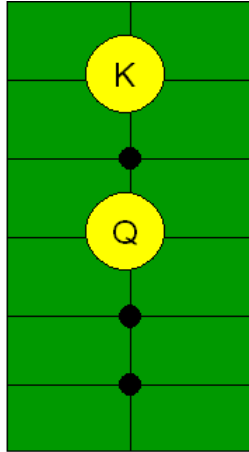
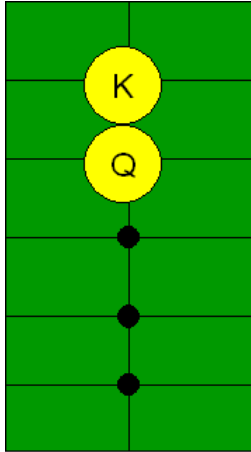



Eurobot 2011 Chess'Up !



Rules 2011

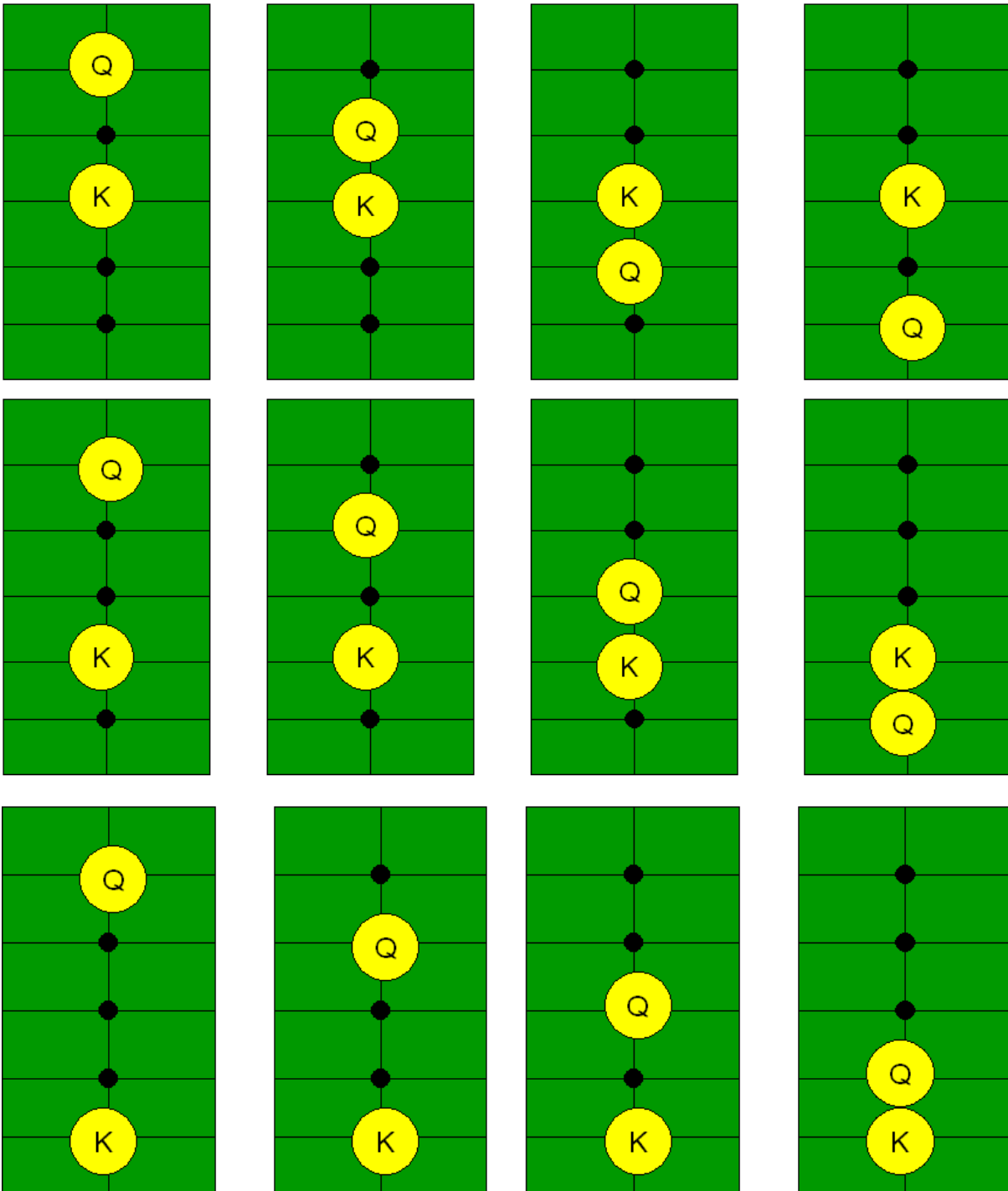



Eurobot 2011
Chess'Up !



Rules 2011

10. Appendix C - Technical drawings

The whole Appendix C section is located in a separate PDF document downloadable along with this document from organizers' website. The Appendix C document is an integral part of these rules.

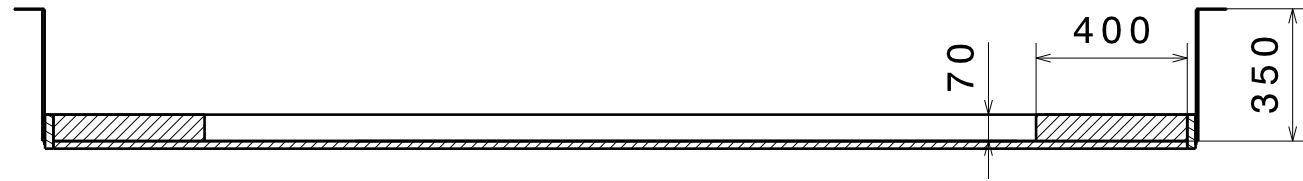

Section A-A

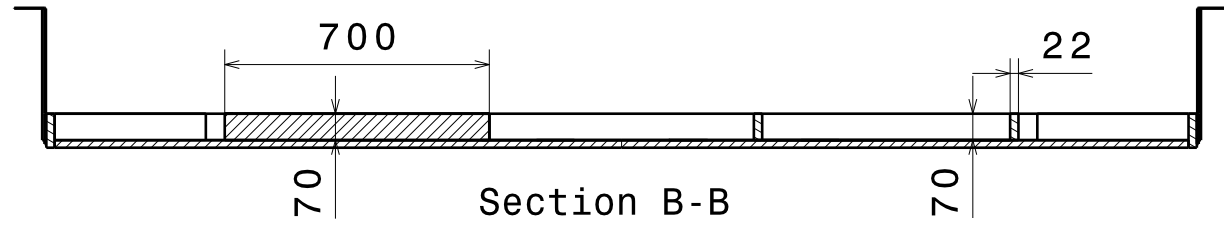

Section B-B

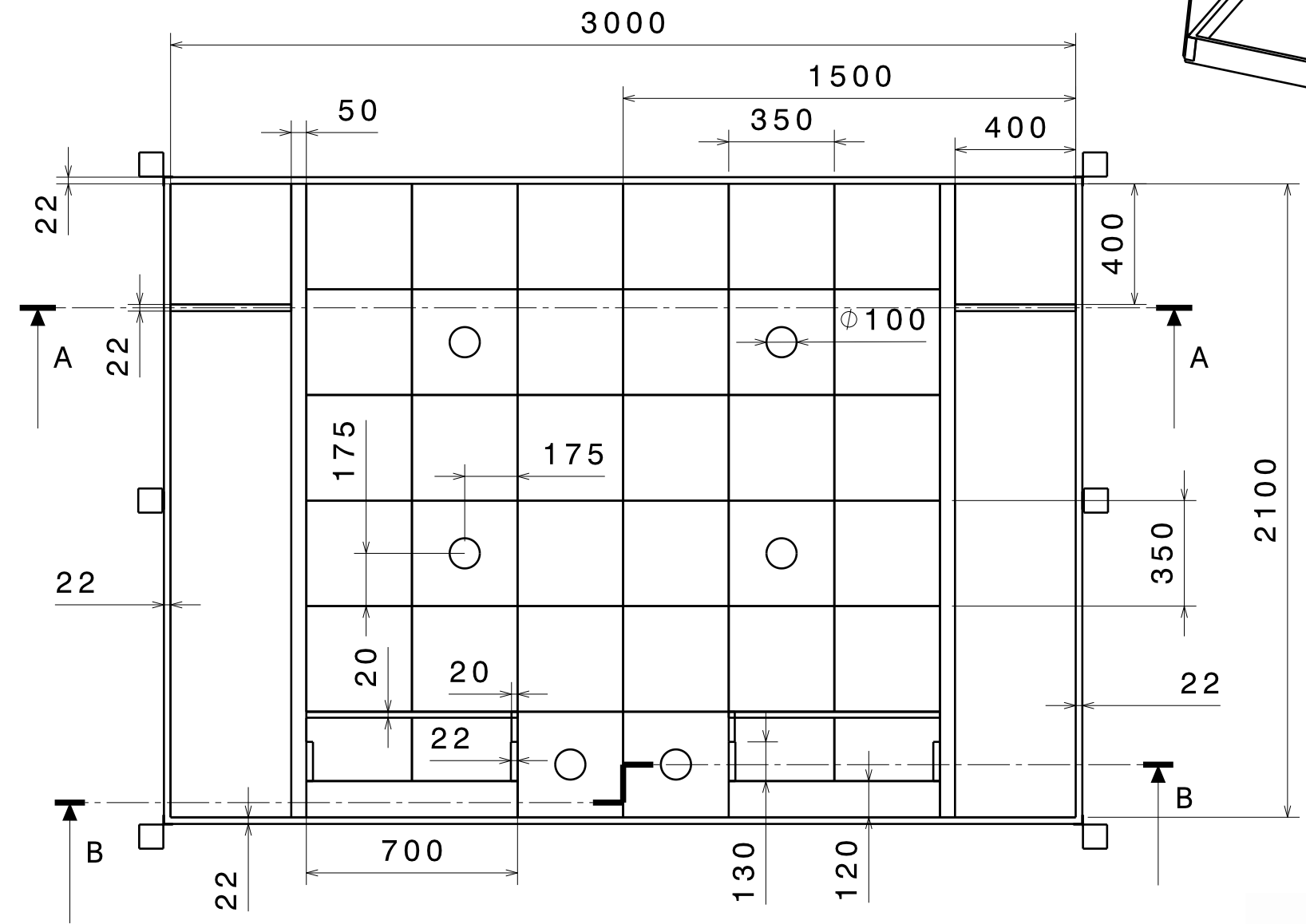
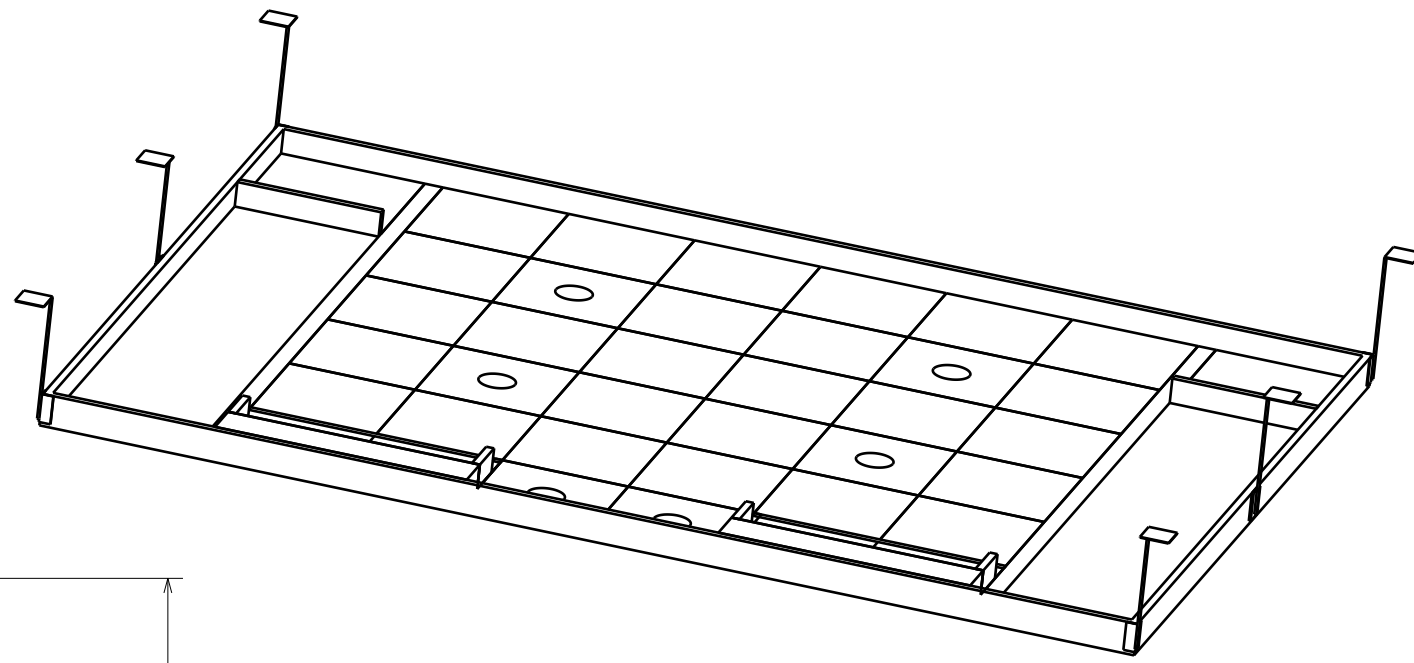

DIMENSIONS ARE IN MILLIMETRES		
EUROBOT 2011		
SPECIFICATION OF THE TABLE AND THE PLAYING ELEMENTS		
VERSION 1.2	AUTOR EUROBOT	DATE 26/09/2010
SCALE 1:20	SHEET 1 / 2	FORMAT A3

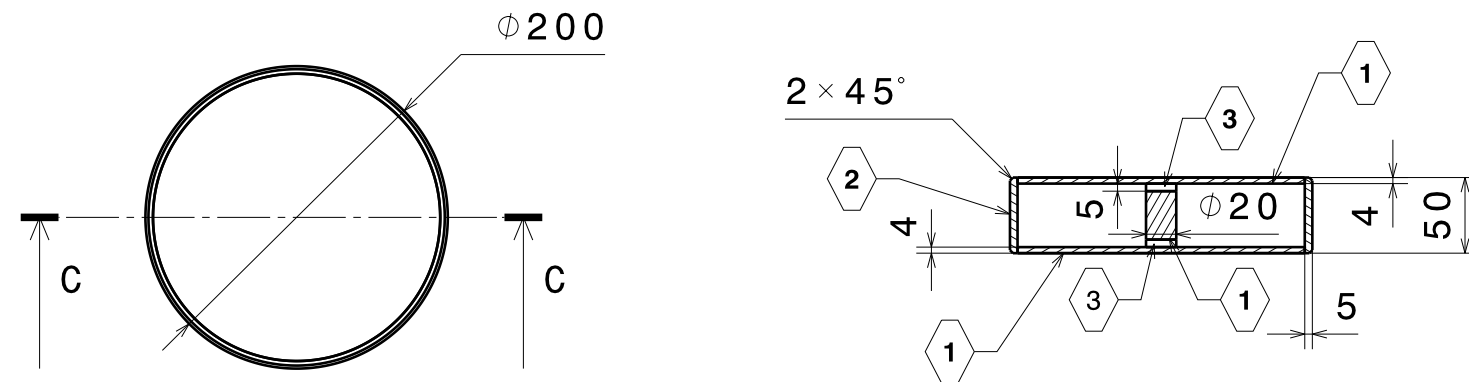

Section C-C

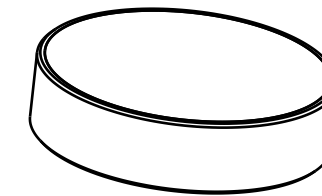

PAWN

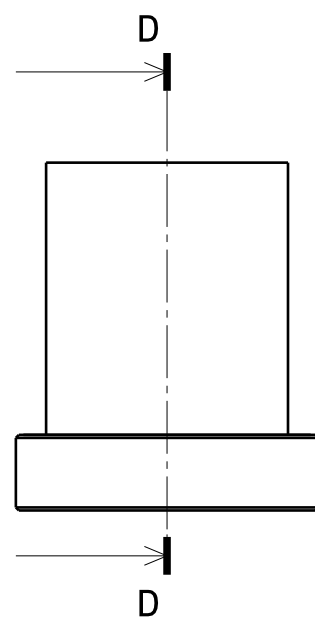

KING

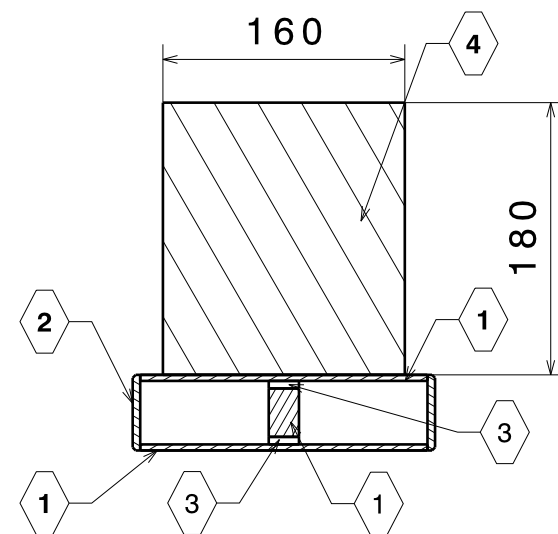

Section D-D

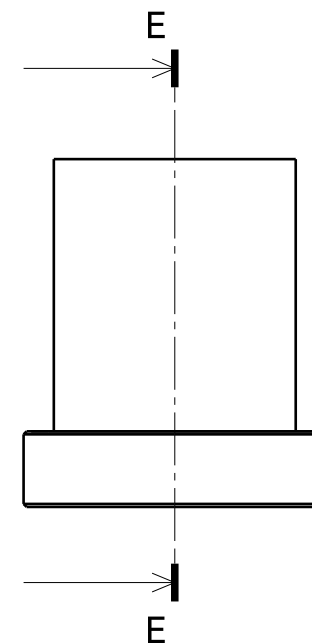

QUEEN

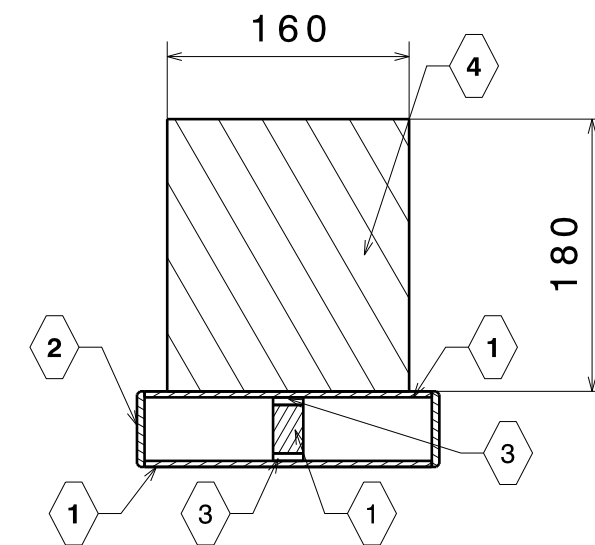

Section E-E

1	Piece of wood
2	Pipe of PVC
3	Magnet
4	Maximun area (cylinder) for the playing element's decoration